

1260 VXI SWITCHING CARD

1260-134 MULTIPLEXER PLUG-IN

PUBLICATION NO. 980824-134

RACAL INSTRUMENTS

United States

(Corporate Headquarters and Service Center)
4 Goodyear Street, Irvine, CA 92618
Tel: (800) 722-2528, (949) 859-8999; Fax: (949) 859-7139

5730 Northwest Parkway Suite 700, San Antonio, TX 78249
Tel: (210) 699-6799; Fax: (210) 699-8857

Europe

(European Headquarters and Service Center)
18 Avenue Dutartre, 78150 LeChesnay, France
Tel: +33 (0)1 39 23 22 22; Fax: +33 (0)1 39 23 22 25

29-31 Cobham Road, Wimborne, Dorset BH21 7PF, United Kingdom
Tel: +44 (0) 1202 872800; Fax: +44 (0) 1202 870810

Via Milazzo 25, 20092 Cinisello B, Milan, Italy
Tel: +39 (0)2 6123 901; Fax: +39 (0)2 6129 3606

Technologie Park, Friedrich Ebert Strasse, 51429 Bergisch Gladbach, Germany
Tel: +49 (0) 2204 844200; Fax: +49 (0) 2204 844219

info@racalinstruments.com
sales@racalinstruments.com
helpdesk@racalinstruments.com
<http://www.racalinstruments.com/>



PUBLICATION DATE: August 05, 2003

Copyright 1998 by Racal Instruments, Inc. Printed in the United States of America. All rights reserved.
This book or parts thereof may not be reproduced in any form without written permission of the publisher.

THANK YOU FOR PURCHASING THIS RACAL INSTRUMENTS PRODUCT.

For this product, or any other Racal Instruments product that incorporates software drivers, you may access our web site to verify and/or download the latest driver versions. The web address for driver downloads is:

<http://www.racalstruments.com/downloads>

You will be asked to register one time only to gain access to the driver and product manual downloads sections. At registration a cookie will be placed on your computer if you choose to accept it. This is done to facilitate your use of these sections on future visits. You may refuse to accept the cookie and still have complete access to the software driver database but will have to re-register every time you visit. This cookie is for ease of use only and no information is gathered for, sold, or reported to, any third party organization.

If you have any questions about software driver downloads or our privacy policy, please contact us at info@racalstruments.com.

WARRANTY STATEMENT

All Racal Instruments, Inc. products are designed and manufactured to exacting standards and in full conformance to Racal's ISO 9001 procedures.

This warranty does not apply to defects resulting from any modification(s) of any product or part without Racal's express written consent, or misuse of any product or part. The warranty also does not apply to fuses, software, non-rechargeable batteries, damage from battery leakage, or problems arising from normal wear, such as mechanical relay life, or failure to follow instructions.

This warranty is in lieu of all other warranties, expressed or implied, including any implied warranty of merchantability or fitness for a particular use. The remedies provided herein are buyer's sole and exclusive remedies.

For the specific terms of your standard warranty, or optional extended warranty or service agreement, contact your Racal customer service advisor. Please have the following information available to facilitate service.

1. Product serial number
2. Product model number
3. Your company and contact information

You may contact your customer service advisor by:

E-Mail:	Helpdesk@racalstruments.com	
Telephone:	+1 800 722 3262	(USA)
	+44(0) 8706 080134	(UK)
	+852 2405 5500	(Hong Kong)
Fax:	+1 949 859 7309	(USA)
	+44(0) 1628 662017	(UK)
	+852 2416 4335	(Hong Kong)

RETURN of PRODUCT

Authorization is required from Racal Instruments before you send us your product for service or calibration. Call your nearest Racal Instruments support facility. A list is located on the last page of this manual. If you are unsure where to call, contact Racal Instruments, Inc. Customer Support Department in Irvine, California, USA at 1-800-722-3262 or 1-949-859-8999 or via fax at 1-949-859-7139. We can be reached at: helpdesk@racalstruments.com.

PROPRIETARY NOTICE

This document and the technical data herein disclosed, are proprietary to Racal Instruments, and shall not, without express written permission of Racal Instruments, be used, in whole or in part to solicit quotations from a competitive source or used for manufacture by anyone other than Racal Instruments. The information herein has been developed at private expense, and may only be used for operation and maintenance reference purposes or for purposes of engineering evaluation and incorporation into technical specifications and other documents which specify procurement of products from Racal Instruments.

DISCLAIMER

Buyer acknowledges and agrees that it is responsible for the operation of the goods purchased and should ensure that they are used properly and in accordance with this handbook and any other instructions provided by Seller. RII products are not specifically designed, manufactured or intended to be used as parts, assemblies or components in planning, construction, maintenance or operation of a nuclear facility, or in life support or safety critical applications in which the failure of the RII product could create a situation where personal injury or death could occur. Should Buyer purchase RII product for such unintended application, Buyer shall indemnify and hold RII, its officers, employees, subsidiaries, affiliates and distributors harmless against all claims arising out of a claim for personal injury or death associated with such unintended use.

FOR YOUR SAFETY

Before undertaking any troubleshooting, maintenance or exploratory procedure, read carefully the **WARNINGS** and **CAUTION** notices.



CAUTION
RISK OF ELECTRICAL SHOCK
DO NOT OPEN



This equipment contains voltage hazardous to human life and safety, and is capable of inflicting personal injury.



If this instrument is to be powered from the AC line (mains) through an autotransformer, ensure the common connector is connected to the neutral (earth pole) of the power supply.



Before operating the unit, ensure the conductor (green wire) is connected to the ground (earth) conductor of the power outlet. Do not use a two-conductor extension cord or a three-prong/two-prong adapter. This will defeat the protective feature of the third conductor in the power cord.



Maintenance and calibration procedures sometimes call for operation of the unit with power applied and protective covers removed. Read the procedures and heed warnings to avoid “live” circuit points.

Before operating this instrument:

1. Ensure the proper fuse is in place for the power source to operate.
2. Ensure all other devices connected to or in proximity to this instrument are properly grounded or connected to the protective third-wire earth ground.

If the instrument:

- fails to operate satisfactorily
- shows visible damage
- has been stored under unfavorable conditions
- has sustained stress

Do not operate until, performance is checked by qualified personnel.

Racal Instruments

EC Declaration of Conformity

We

Racal Instruments Inc.
4 Goodyear Street
Irvine, CA 92718

declare under sole responsibility that the

1260-134 Multiplexer Plug In Module
P/N 407662

conforms to the following Product Specifications:

Safety: EN 61010-1

EMC: EN50081-1

CISPR 11:1990/EN 55011 (1991): Group 1 Class A

IEC 801-2:1991/EN 50082-1 (1992): 4 kV CD, 8 kV AD

IEC 801-3:1984/EN 50082-1 (1992): 3 V/m, 27-500 MHz

IEC 801-4:1988/EN 50082-1 (1992): 1 kV

Supplementary Information:

The above specifications are met when the product is installed in a Racal Instruments Adapt-a-Switch Carrier with faceplates installed over all unused slots, as applicable. The carrier is installed in a certified mainframe.

The product herewith complies with the requirements of the Low Voltage Directive 73/23/EEC and the EMC Directive 89/336/EEC.

Irvine, CA, November 12, 1998

Quality Manager

This page was left intentionally blank.

Table of Contents

Chapter 1	1-1
SPECIFICATIONS	1-1
Introduction	1-1
Specifications	1-2
About MTBF	1-3
Ordering Information	1-4
Chapter 2	2-1
INSTALLATION INSTRUCTIONS	2-1
Unpacking and Inspection	2-1
Reshipment Instructions	2-1
Installation	2-1
Module Configuration	2-2
Front Panel Connectors	2-2
Mating Connectors	2-7
Chapter 3	3-1
MODULE OPERATION	3-1
Setting the Module Address	3-1
Operating Modes	3-2
Operating In Message-Based Mode	3-4
Channel Descriptors For The 1260-134	3-4
Reply To The MOD:LIST? Command	3-5
Operating The 1260-134 in Register-Based Mode	3-5
1260-134 Example Code	3-9
Chapter 4	4-1
OPTIONAL ASSEMBLIES	4-1

Chapter 5 5-1

PRODUCT SUPPORT 5-1

 Product Support 5-1

 Reshipment Instructions 5-1

 Support Offices 5-2

List of Figures

Figure 1-1, The 1260-134	1-1
Figure 2-1, Block Diagram of 1260-134	2-3
Figure 2-2, Front-Panel Connector Pin Numbering	2-4
Table 2-1, 1260-134 Front-Panel Connections	2-5
Figure 3-3, Message-Based Mode of Operation	3-3
Figure 3-4, Register-Based Mode of Operation.....	3-3

List of Tables

Table 2-1, 1260-134 Front-Panel Connections	2-5
---	-----

This page was left intentionally blank.

Chapter 1

SPECIFICATIONS

Introduction

The 1260-134 is a 16 (1X4) 2 wire multiplexer plug-in switch module developed for the Racal Instruments 1260-100 Adapt-a-Switch Carrier. The 1260-134 includes the following features:

- Standard Adapt-a-Switch plug-in design, providing for ease of replacement
- Data-Driven embedded descriptor, allowing immediate use with any Option-01T switch controller, regardless of firmware revision level.

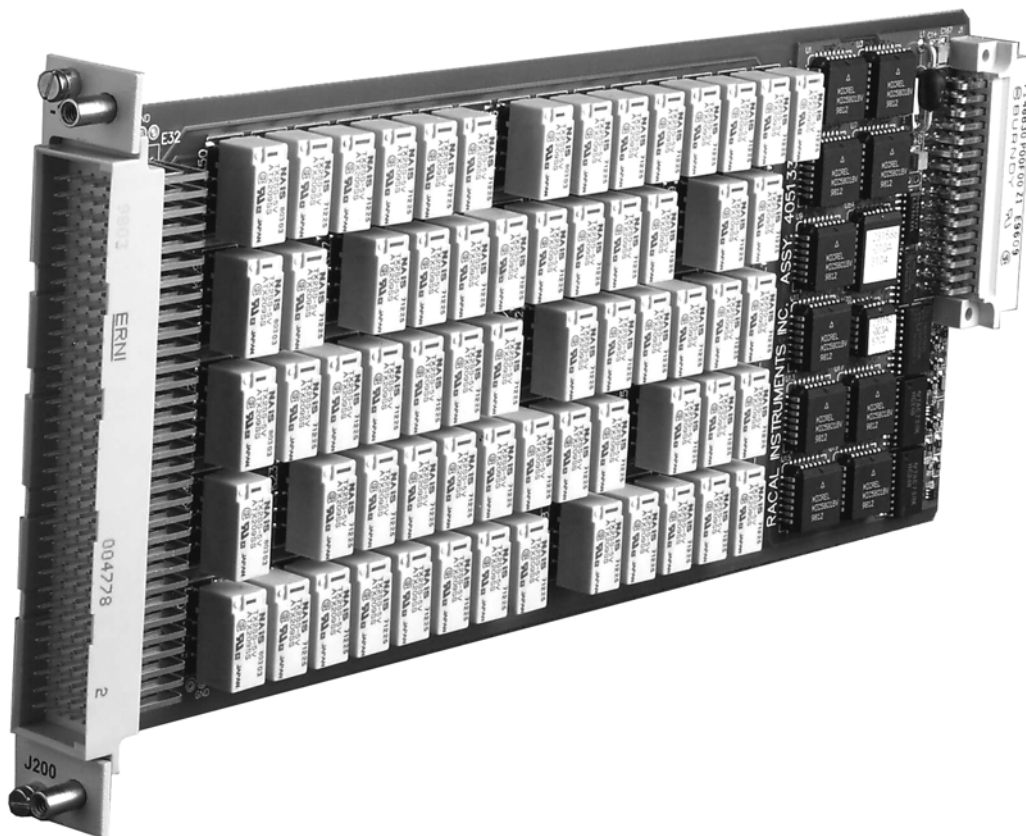

Figure 1-1, The 1260-134

Specifications

Bandwidth (-3dB)	100 MHz
Insertion Loss	
10 MHz	< 0.5 dB
50 MHz	< 1 dB
Isolation	
100 KHz	> 50 dB
1 MHz	> 40 dB
Crosstalk	
100 KHz	< -50 dB
1 MHz	< -40 dB
Switching Voltage	
AC	250 V, Max
DC	220 V, Max
Switching Current	
AC	2 A, Max
DC	2 A, Max
Switching Power	
AC	125 VA, Max
DC	60 W, Max
Path resistance	< 500 m Ω
Thermal EMF	< 10 μ V
Capacitance	
Channel to Chassis	< 100 pF
Open Channel	< 5 pF
Insulation resistance	> 10 ⁹ Ω
Relay Settling Time	< 10 ms
Shock	30g, 11 ms, 1/2 sine wave
Vibration	0.013 in. P-P, 5-55 Hz
Bench Handling	4 in., 45°
Cooling	See 1260-100 cooling data
Temperature	
Operating	0°C to +55°C
Non-operating	-40°C to +75°C
Relative Humidity	85% + 5% non-condensing at

	< 30°C
Altitude	
Operating	10,000 feet
Non-operating	15,000 feet
Power Requirements	
+5 VDC	150mA + 30mA per energized relay (2A Max.)
Weight	1.0 lb. (0.45 kg.)
MTBF	749095 hours (MIL-HDBK-217E)
Dimensions	4.5"H X 0.75"W X 9.5"D

About MTBF

The 1260-134 MTBF is 749095 hours, calculated in accordance with MIL-HDBK-217E, with the exception of the electromechanical relays. Relays are excluded from this calculation because relay life is strongly dependent upon operating conditions. Factors affecting relay life expectancy are:

1. Switched voltage
2. Switched current
3. Switched power
4. Maximum switching capacity
5. Maximum rated carrying current
6. Load type (resistive, inductive, capacitive)
7. Switching repetition rate
8. Ambient temperature

The most important factor is the maximum switching capacity, which is an interrelationship of maximum switching power, maximum switching voltage and maximum switching current. When a relay operates at a lower percentage of its maximum switching capacity, its life expectancy is longer. The maximum switching capacity specification is based on a resistive load, and must be further de-rated for inductive and capacitive loads.

For more details about the above life expectancy factors, refer to the data sheet for the switch plug-in module.

The relay used on the 1260-134 plug-in is Racal part no. 310256-001. The relay manufacturer's specifications for this relay are:

Life Expectancy	
Mechanical	100,000,000 operations
Electrical	100,000 operations at full rated load (resistive)

For additional relay specifications, refer to the relay manufacturer's data sheet.

Ordering Information

Listed below are part numbers for both the 1260-134 switch module and available mating connector accessories. Each 1260-134 uses a single mating connector.

ITEM	DESCRIPTION	PART #
1260-134 Switch Module	Switch Module, 16 (1X4) 2 wire multiplexer, 2 A Consisting of: P/N 405133-001 PCB Assembly P/N 980824-134 Manual	407662
160-pin Mating Connector	160 Pin Conn. Kit with pins	407664
Cable Assy. 6ft, Sleeved	160 Pin Cable Assy, 6 Ft, 24 AWG	407408-001
Additional Manual		980824-134

INSTALLATION INSTRUCTIONS

Unpacking and Inspection

1. Before unpacking the switching module, check the exterior of the shipping carton for any signs of damage. All irregularities should be noted on the shipping bill and reported.
2. Remove the instrument from its carton, preserving the factory packaging as much as possible.
3. Inspect the switching module for any defects or damage. Immediately notify the carrier if any damage is apparent.
4. Have a qualified person check the instrument for safety before use.

Reshipment Instructions

1. Use the original packing material when returning the switching module to Racal Instruments for servicing. The original shipping carton and the instrument's plastic foam will provide the necessary support for safe reshipment.
2. If the original packing material is unavailable, wrap the switching module in an ESD Shielding bag and use plastic spray foam to surround and protect the instrument.
3. Reship in either the original or a new shipping carton.

Installation

Installation of the 1260-134 Switching Module into a 1260-100 Carrier assembly is described in the Installation section of the 1260-100 Adapt-a-Switch Carrier Manual.

Module Configuration

The 1260-134 contains sixteen 1x4 multiplexers. Each channel of each multiplexer is independently controlled. Thus, the user can simultaneously connect any combination of four input channels to the common port of the multiplexer.

For a block diagram of the 1260-134, refer to **Figure 2-1**.

Front Panel Connectors

The 1260-134 has one 160-pin front-panel connector, labeled J200. It is a 160-pin, modified DIN style, with 0.025" square posts as pins. It has one pin for each input and one for each output. See **Figure 2-2** for numbering. **Table 2-1** shows the mapping of channel numbers to connector pins. Information about available mating connectors is provided immediately after **Table 2-1**.

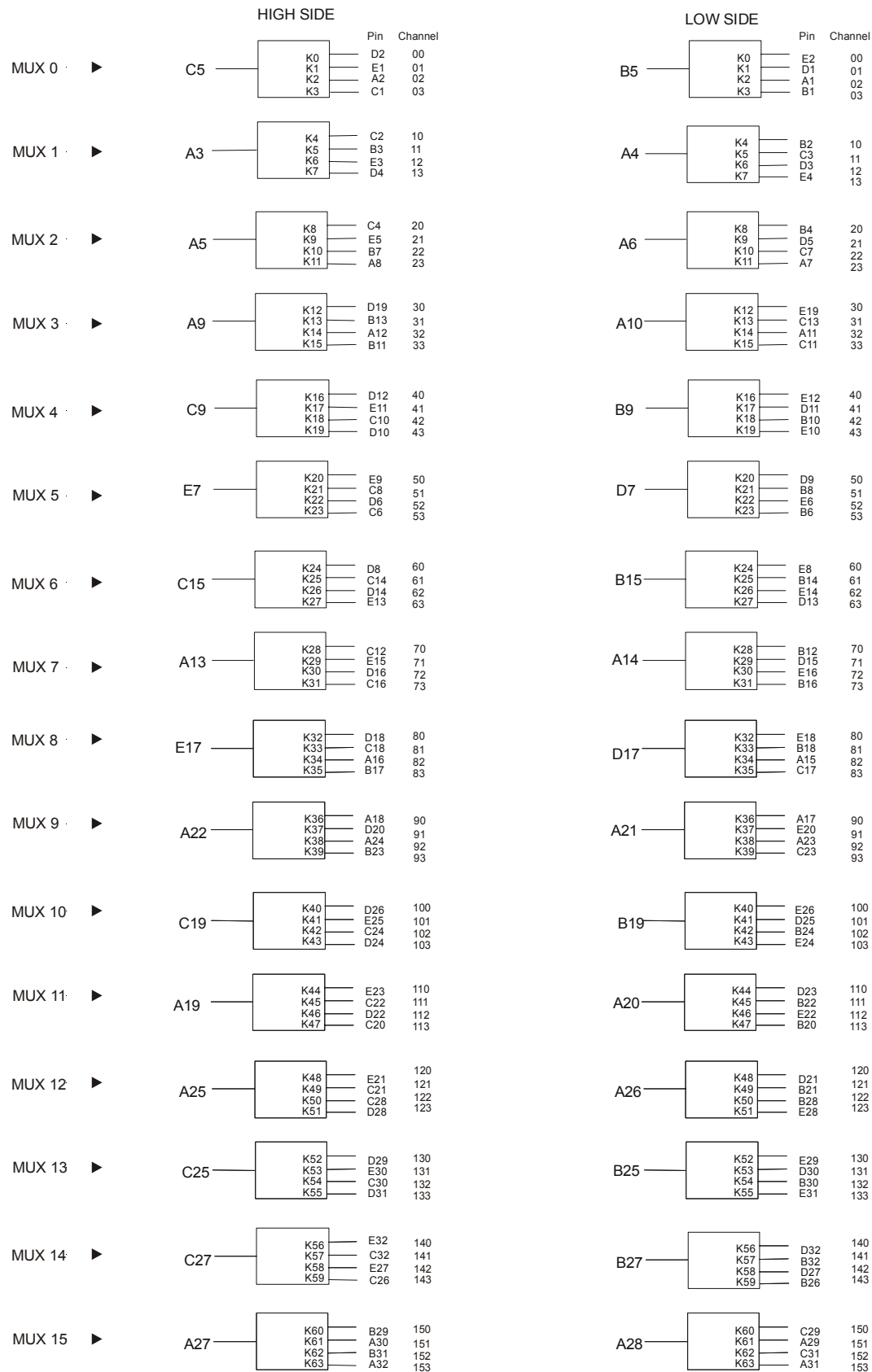

Figure 2-1, Block Diagram of 1260-134

Figure 2-2, Front-Panel Connector Pin Numbering

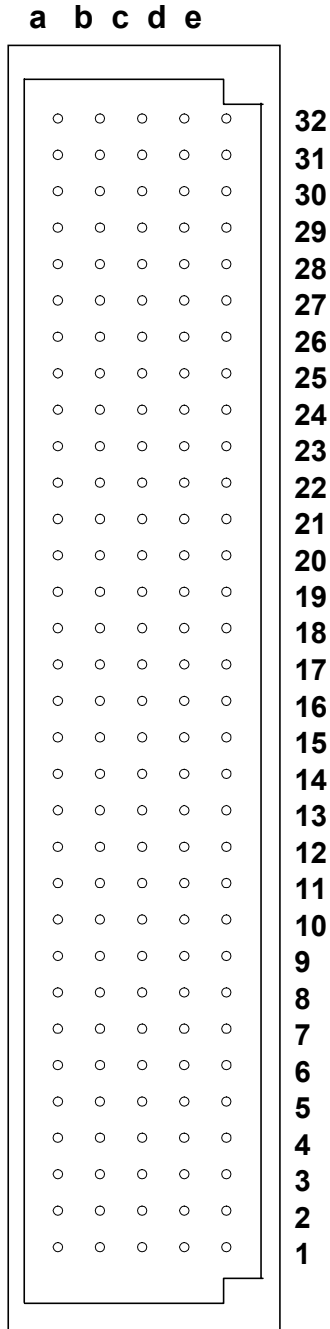

Table 2-1, 1260-134 Front-Panel Connections

MUX	Channel	Pin	
		High	Low
0	Common	C5	B5
	Input 0	D2	E2
	Input 1	E1	D1
	Input 2	A2	A1
	Input 3	C1	B1
1	Common	A3	A4
	Input 10	C2	B2
	Input 11	B3	C3
	Input 12	E3	D3
	Input 13	D4	E4
2	Common	A5	A6
	Input 20	C4	B4
	Input 21	E5	D5
	Input 22	B7	C7
	Input 23	A8	A7
3	Common	A9	A10
	Input 30	D19	E19
	Input 31	B13	C13
	Input 32	A12	A11
	Input 33	B11	C11
4	Common	C9	B9
	Input 40	D12	E12
	Input 41	E11	D11
	Input 42	C10	B10
	Input 43	D10	E10
5	Common	E7	D7
	Input 50	E9	D9
	Input 51	C8	B8
	Input 52	D6	E6
	Input 53	C6	B6
6	Common	C15	B15
	Input 60	D8	E8
	Input 61	C14	B14
	Input 62	D14	E14
	Input 63	E13	D13
7	Common	A13	A14
	Input 70	C12	B12
	Input 71	E15	D15
	Input 72	D16	E16
	Input 73	C16	B16

MUX	Channel	Pin	
		High	Low
8	Common	E17	D17
	Input 80	D18	E18
	Input 81	C18	B18
	Input 82	A16	A15
	Input 83	B17	C17
9	Common	A22	A21
	Input 90	A18	A17
	Input 91	D20	E20
	Input 92	A24	A23
	Input 93	B23	C23
10	Common	C19	B19
	Input 100	D26	E26
	Input 101	E25	D25
	Input 102	C24	B24
	Input 103	D24	E24
11	Common	A19	A20
	Input 110	E23	D23
	Input 111	C22	B22
	Input 112	D22	E22
	Input 113	C20	B20
12	Common	A25	A26
	Input 120	E21	D21
	Input 121	C21	B21
	Input 122	C28	B28
	Input 123	D28	E28
13	Common	C25	B25
	Input 130	D29	E29
	Input 131	E30	D30
	Input 132	C30	B30
	Input 133	D31	E31
14	Common	C27	B27
	Input 140	E32	D32
	Input 141	C32	B32
	Input 142	E27	D27
	Input 143	C26	B26
15	Common	A27	A28
	Input 150	B29	C29
	Input 151	A30	A29
	Input 152	B31	C31
	Input 153	A32	A31

Mating Connectors

Mating connector accessories are available:

160-Pin Connector Kit with pins, P/N 407664

160-Pin Cable Assembly, 6 Ft., 24 AWG,
P/N 407408-001

The 160-Pin Connector Kit consists of a connector housing and 170 crimp pins. After wire attachment, the pin is inserted into the housing and will snap into place, providing positive retention.

The suggested hand tool for the crimp pins is P/N 990898. The corresponding pin removal tool is P/N 990899.

The 160-Pin Cable Assembly uses 24 AWG cable with crimp pins to mate with the 1260-134. The other cable end is unterminated. Refer to **Table 2-1** for channel-to-pin mapping information.

This page was left intentionally blank.

Chapter 3

MODULE OPERATION

Setting the Module Address

The Option-01T switch controller identifies each Adapt-a-Switch plug-in or conventional 1260-Series module by a *module address* that is unique to that module. The module address is a number from 1 through 12, inclusive.

The module address assigned to the 1260-134 depends on the carrier slot into which the 1260-134 is inserted, and on the position of the logical address DIP switch on the carrier side panel. The switch has two settings:

- 1-6 (closed): When the switch is set to this position, the module addresses of the plug-ins in the 1260-100 Carrier are from 1 through 6. The module with address 1 is in the left slot of the top row. The plug-ins are addressed in the following pattern:

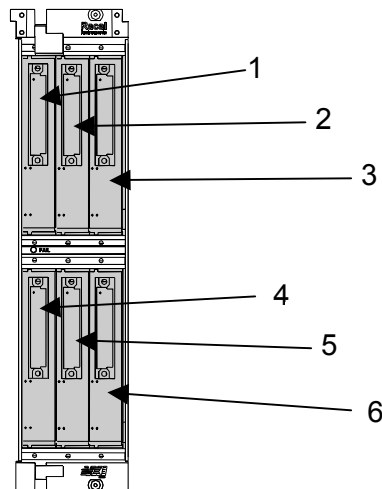

Figure 3-1, Front View – Module Addresses for 1 through 6

- 7 - 12 (open): When the switch is set to this position, the module addresses of the plug-ins in the 1260-100 Carrier are from 7 through 12, in the following pattern:

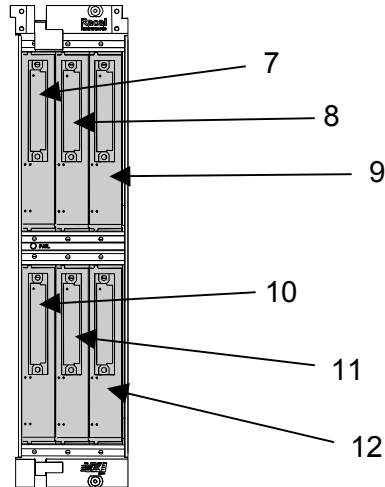

Figure 3-2 Front View – Module Addresses for 7 through 12

When setting module addresses for Adapt-a-Switch Carriers and conventional 1260-Series modules, be sure that no address is used by more than one plug-in or 1260-Series C-Size switching module.

For instructions on setting module addresses for a conventional 1260-Series module, see the label on the side panel of the module.

Operating Modes

The 1260-134 may be operated either in *message-based* mode or in *register-based* mode.

In the *message-based* mode, the 1260-01T switch controller interprets commands sent by the slot 0 controller, and determines the appropriate data to send to the control registers of the 1260-134 module.

A conceptual view of the message-based mode of operation is shown in **Figure 3-3**.

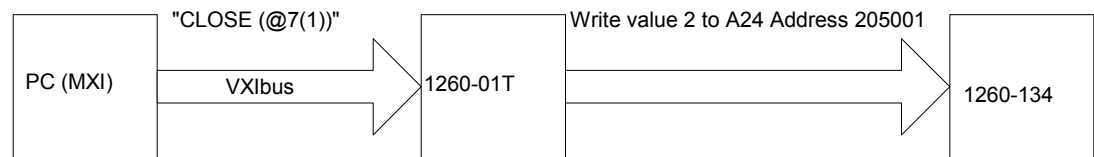

Figure 3-3, Message-Based Mode of Operation

In the *register-based* mode, the user writes directly to the control registers on the 1260-134 module. The 1260-01T command module does not monitor these operations, and does not keep track of the relay states on the 1260-134 module in this mode.

A conceptual view of the register-based mode is shown in **Figure 3-4** below.

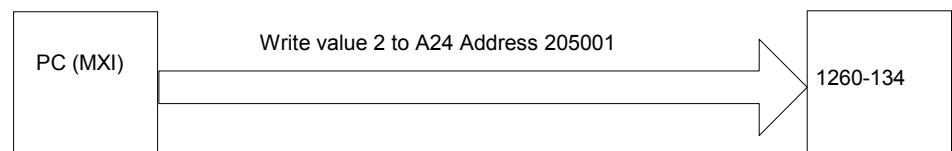

Figure 3-4, Register-Based Mode of Operation

Since the 1260-01T switch controller does not keep track of relay states during the register-based mode, it is advisable to use **either** the message-based or the register-based mode, and continue to use the same mode throughout the application program.

In general, the message-based mode of operation is easier to use with utility software such as the National Instruments VXI Interactive Control (VIC) program. The message-based mode allows the user to send ASCII text commands to the 1260-01T and to read replies from the 1260-01T. In addition, some features, such as the SCAN list, are available only in the message-based mode of operation.

The register-based mode provides faster control of relay channels. In this mode, relay operations are processed in less than 9 microseconds, not counting relay settling time or software overhead inherent in I/O libraries such as VISA. To determine the

relay settling time, refer to Relay Settling Time in the Specifications section.

Consult the 1260-01T User's Manual for a comparison of the message-based and register-based modes of operation.

Operating In Message-Based Mode

Channel Descriptors For The 1260-134

The standard 1260-01T commands are used to operate the 1260-134 module. These commands are described in the 1260-01T User's Manual.

Each 1260-01T relay command uses a *channel descriptor* to select the channel(s) of interest. The syntax for a channel descriptor is the same for all 1260 series modules. In general, the following syntax is used to select a single channel:

```
(@ <module address> ( <channel> ) )
```

Where:

- <module address> is the address of the 1260-134 module. This is a number in the range from 1 through 12, inclusive.
- <channel> is the 1260-134 channel to operate. This is a number in the range from 0-3, 10-13, 20-23etc. See Table 2-1.

Multiple individual channels may be specified using the following channel descriptor syntax:

```
@ <module address> ( <chan1> , <chan2>  
, . . . , <chanN> ) )
```

A range of channels may be specified using the following channel descriptor syntax:

```
@ <module address> ( <first channel> :  
<last channel> ) )
```

The following examples illustrate the use of the channel descriptors for the 1260-134:

OPEN (@8 (0))	Open channel 0 on the 1260-134 that has module address 8.
CLOSE (@8 (0, 3))	Close channels 0 and 3 on the

1260-134 that has module address 8.

CLOSE (@2(10:13)) Close channels 10 through 13 inclusive on the 1260-134 that has module address 2.

Reply To The MOD:LIST? Command

The 1260-01T returns a reply to the MOD:LIST? command. This reply is unique for each different 1260 series switch module. The syntax for the reply is:

<module address> : <module-specific identification string>

The <module-specific identification string> for the 1260-134 is:

1260-134 16 1X4 2A MUX

So, for a 1260-134 whose <module address> is set to 8, the reply to this query would be:

8: 1260-134 16 1X4 2A MUX

Operating The 1260-134 in Register-Based Mode

In register-based mode, the 1260-134 is operated by directly writing and reading control registers on the 1260-134 module. For the channel assignments for each control register, see Table 3-1.. When a control register is written to, all channels controlled by that register are operated simultaneously.

The control registers are located in the VXIbus A24 Address Space. The A24 address for a control register depends on:

1. The A24 Address Offset assigned to the 1260-01T module by the Resource Manager program. The Resource Manager program is provided by the VXIbus slot-0 controller vendor. The A24 Address Offset is placed into the "Offset Register" of the 1260-01T by the Resource Manager.
2. The <module address> of the 1260-134 module. This is a value in the range from 1 and 12 inclusive.
3. The 1260-134 control register to be written to or read from. Each control register on the 1260-134 has a unique address.

The base A24 address for the 1260-134 module may be calculated by:

$$(A24 \text{ Offset of the } 1260-01T) + (1024 \times \text{Module Address of } 1260-134).$$

The A24 address offset is usually expressed in hexadecimal. A typical value of 204000_{16} is used in the examples that follow.

A 1260-134 with a module address of 7 would have the base A24 address computed as follows:

$$\begin{aligned} \text{Base A24 Address of } 1260-134 &= 204000_{16} + (400_{16} \times 7_{10}) \\ &= 205C00_{16} \end{aligned}$$

The control registers for Adapt-a-Switch plug-ins and conventional 1260-Series modules are always on odd-numbered A24 addresses. The three control registers for the 1260-134 reside at the first three odd-numbered A24 addresses for the module:

$$(\text{Base A24 Address of } 1260-134) + 1 = \text{Control Register 0}$$

$$(\text{Base A24 Address of } 1260-134) + 3 = \text{Control Register 1}$$

$$(\text{Base A24 Address of } 1260-134) + 5 = \text{Control Register 2}$$

So, for our example, the first three control registers are located at:

205C01	Control Register 0, controls channels 150, 143, 142, etc.
205C03	Control Register 1, controls channels 153, 151, 141, etc.
205C05	Control Register 2, controls channels 93, 100, 101, etc.

Table 3-1 shows the channel assignments for each control register.

Table 3-1, Control Register Channel Assignments

Control Register	Channels							
	Bit 7 (MSB)	Bit 6	Bit 5	Bit 4	Bit 3	Bit 2	Bit 1	Bit 0 (LSB)
0	130	131	132	133	140	142	143	150
1	152	122	123	Unused	Unused	141	151	153
2	113	Unused	120	121	101	100	Unused	93
3	92	81	111	112	110	103	102	Unused
4	72	73	Unused	80	82	83	90	91
5	32	31	Unused	61	62	63	70	71
6	53	52	51	42	41	40	Unused	33
7	3	10	11	30	23	Unused	60	Unused
8	2	13	43	50	Unused	20	21	22
9	12	Unused	Unused	Unused	Unused	Unused	0	1

Setting a control bit to 1 closes the corresponding channel, and clearing the bit to zero opens the corresponding channel. Thus, if you write the value 1000 0101 binary = 133 decimal = 85 hexadecimal to Control Register 0, channels 130, 142, and 150 will close, while channels 131, 132, 133, 140, and 143 will open.

The present control register value may be read back by reading an 8-bit value from the control register address. **The value is inverted.** In other words, the eight-bit value read back is the one's complement of the value written.

If you want to change the state of a single relay without affecting the present state of the other relays controlled by the control register, you must:

1. Read the control register
2. Invert the bits (perform a one's complement on the register data)
3. Perform a bit-wise AND operation, leaving all but the specific control register bit for the relay to change
4. **To open:** continue to step 5. **To close:** OR in the bit for the relay to close.
5. Write the modified value back to the control register.

For example, to close channel 123:

1. Read Control Register 1 (this register controls channels 122, 123, 141, 151, 152, and 153 with channel 153 represented by the LSB)
2. Invert the bits in the value read in step 1
3. AND with 1101 1111 binary (the zero is in the position corresponding to channel 123)
4. OR with 0010 0000 binary
5. Write the value to Control Register 1

The VISA I/O library may be used to control the module. The VISA function `viOut8()` is used to write a single 8-bit byte to a control register, while `viIn8()` is used to read a single 8-bit byte from the control register. The following code example shows the use of `viOut8()` to update the 1260-134 module.

1260-134 Example Code

```
#include <visa.h>

/* This example shows a 1260-01T at logical address 16 and a VXI/MXI */
/* interface */
#define RI1260_01_DESC      "VXI::16"

/* For a GPIB-VXI interface, and a logical address of 77 */
/* the descriptor would be: "GPIB-VXI::77" */

/* this example shows a 1260-134 with module address 7 */
#define MOD_ADDR_134  7

void example_operate_1260_134(void)
{
    ViUInt8 creg_val;
    ViBusAddress creg0_addr;
    ViBusAddress creg1_addr;
    ViBusAddress creg2_addr;
    ViSession hdl1260;    /* VISA handle to the 1260-01T */
    ViSession hdlRM;     /* VISA handle to the resource manager */
    ViStatus error;      /* VISA error code */

    /* open the resource manager */
    /* this must be done once in application program */
    error = viOpenDefaultRM (&hdlRM);

    if (error < 0) {
        /* error handling code goes here */
    }

    /* get a handle for the 1260-01T */
    error = viOpen (hdlRM, RI1260_01_DESC, VI_NULL,VI_NULL, &hdl1260);
    if (error < 0) {
        /* error handling code goes here */
    }

    /* form the offset for control register 0 */
    /* note that the base A24 Address for the 1260-01T */

```

```
/* is already accounted for by VISA calls viIn8() and */
/* viOut8() */

    /* module address shifted 10 places = module address x 1024 */
    creg0_addr = (MOD_ADDR_134 << 10) + 1;
    creg1_addr = creg0_addr + 2;
    creg2_addr = creg1_addr + 2;

/* close channel 123 without affecting the state of */
/* channels 122, 141, 151, 152, and 153 */
error = viIn8 (hdl1260, VI_A24_SPACE, creg1_addr, &creg_val);
if (error < 0) {
    /* error handling code goes here */
}

/* invert the bits to get the present control register value */
creg_val = ~creg_val;

/* AND to leave every channel except 123 unchanged */
creg_val &= ~ (0x20);

/* OR in the bit to close channel 123 */
creg_val |= 0x20;

/* write the updated control register value */
error = viOut8 (hdl1260, VI_A24_SPACE, creg1_addr, creg_val);
if (error < 0) {
    /* error handling code goes here */
}

/* open channel 93 without affecting channels 100, 101, 120, 121,
and 113 */
error = viIn8 (hdl1260, VI_A24_SPACE, creg2_addr, &creg_val);
if (error < 0) {
    /* error handling code goes here */
}

/* invert the bits to get the present control register value */
creg_val = ~creg_val;

/* AND to leave every channel except 93 unchanged */
/* leave bit 0 clear to open channel 93 */
creg_val &= ~ (0x01);

/* write the updated control register value */
error = viOut8 (hdl1260, VI_A24_SPACE, creg2_addr, creg_val);
if (error < 0) {
```



```
        /* error handling code goes here */
    }

    /* close the VISA session */
    error = viClose( hdl1260 );
    if (error < 0) {
        /* error handling code goes here */
    }
}
```

This page was left intentionally blank.

Chapter 4

OPTIONAL ASSEMBLIES

407664	Connector Kit, 160 Pin Crimp.....	4-3
407408-001	Cable Assy, 160 Pin, 6 ft, 24AWG.....	4-4

This page was left intentionally blank.

1260-134 User Manual

RACAL INSTRUMENTS, INC.

Assembly 407664

Connector kit, 160 Pin, Crimp

Rev Date 7/30/98 Revision A

#	Component	Description	U/M	Qty Reqd.	REF
1	602258-116	CON-CAB-RCP160C,100S	-E EA	1.000	
2	602258-900	TRMCRP-SNP-U-F26-20G	-E EA	170.000	

4 3 2 1

REVISIONS				
ZONE	REV	DESCRIPTION	DATE	APPROVED
		RELEASED PER DRN NO.		
		RE-RED PER DRN NO.		
		RE-RED PER DRN NO.		
		RE-RED PER DRN NO.		

PROPRIETARY NOTICE	
THE INFORMATION CONTAINED HEREIN IS THE PROPERTY OF RACAL INSTRUMENTS, INC. AND SHALL BE KEPT IN CONFIDENTIALITY. IT IS TO BE USED ONLY FOR THE PURPOSES INTENDED BY RACAL INSTRUMENTS, INC. AND IS NOT TO BE REPRODUCED, COPIED, DISSEMINATED, OR TRANSMITTED IN ANY MANNER WITHOUT THE EXPRESS WRITTEN PERMISSION OF RACAL INSTRUMENTS, INC. ANY UNAUTHORIZED DISCLOSURE OF THIS INFORMATION MAY BE SUBJECT TO LEGAL ACTION. RACAL INSTRUMENTS, INC. ACCEPTS NO LIABILITY FOR ANY DAMAGES, INCLUDING CONSEQUENTIAL DAMAGES, ARISING FROM THE USE OF THIS INFORMATION. RACAL INSTRUMENTS, INC. ACCEPTS NO LIABILITY FOR ANY DAMAGES, INCLUDING CONSEQUENTIAL DAMAGES, ARISING FROM THE USE OF THIS INFORMATION. RACAL INSTRUMENTS, INC. ACCEPTS NO LIABILITY FOR ANY DAMAGES, INCLUDING CONSEQUENTIAL DAMAGES, ARISING FROM THE USE OF THIS INFORMATION. RACAL INSTRUMENTS, INC. ACCEPTS NO LIABILITY FOR ANY DAMAGES, INCLUDING CONSEQUENTIAL DAMAGES, ARISING FROM THE USE OF THIS INFORMATION.	

NOTES:

- SEE WIRE LIST FOR CONTACT ASSIGNMENTS AND CONNECTIONS.
- TERMINATE CABLE INSULATION AS SHOWN, USING SHRINK TUBING (ITEM 10).
- CABLES ARE TO BE BUILT IN PAIRS FOR EASE OF TESTING. TEST CABLE ASSY USING TEST PROCEDURE AND WIRE LIST. ASSEMBLY TO BE MADE UP IN HALF, MAKING TWO SEPARATE CABLE ASSEMBLIES.
- IDENTIFY CABLES AS SHOWN USING INDELEIBLE BLACK SHRINK TUBING (ITEM 11) FOR IDENTIFICATION PROTECTION. SHRINK TUBING (ITEM 11) TO BE CLEAR WITH CLEAR SHRINK TUBING (ITEM 11) FOR IDENTIFICATION PROTECTION. BAG CABLE ASSEMBLY AND IDENTIFY WITH RACAL PART NUMBER 407408-001 AND CURRENT REVISION LETTER.

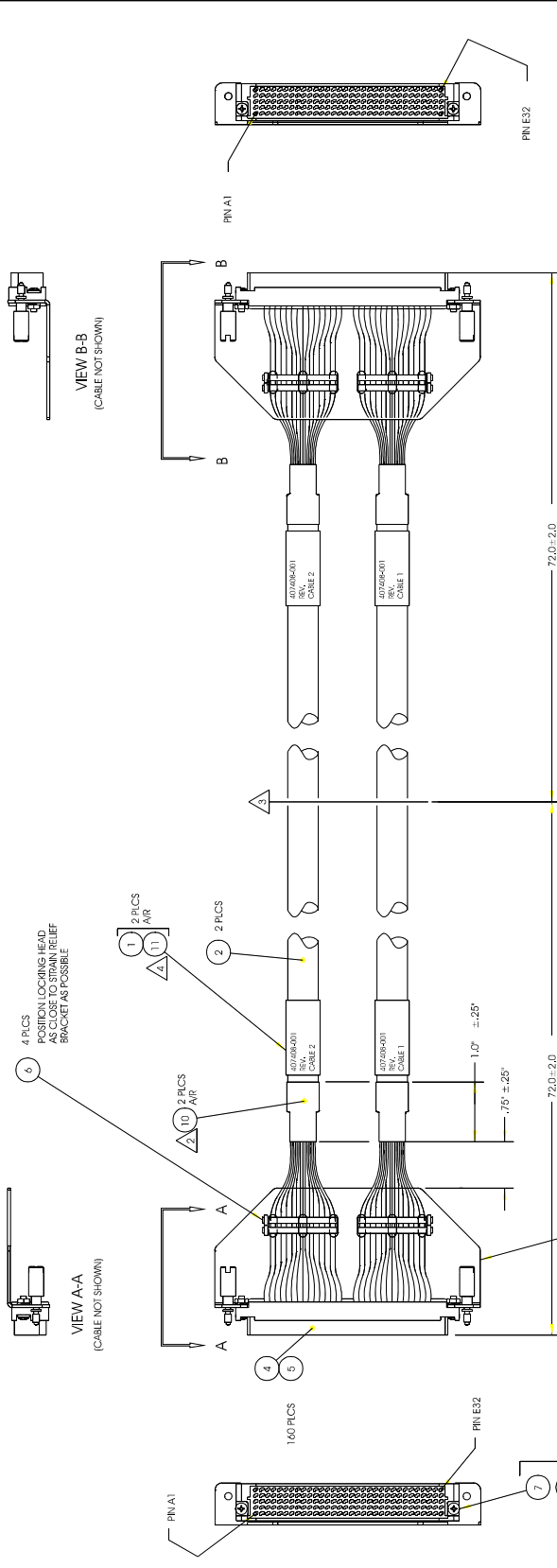

DWG. NO. 407408-001 SH. 1 REV. A

RACAL Instruments, Inc. 4 GOODPAST ST. EMPEROR/CAZ77/9/2002		DATE: 9/20/2002	
TITLE: CABLE ASSY, 160 PIN		REV: C	
PART NO: 407408-001A		REV: 1 OF 18	
DRAWN: BOONMUELL		CHECKED: METZGER	
DESIGNED: METZGER		DATE: 9/20/2002	
PROJECT: 1260-118		SHEET: 1 OF 18	
APPROVED: [Signature]		DATE: 9/20/2002	
ACCOMPLISHED BY: [Signature]		DATE: 9/20/2002	

Chapter 5

PRODUCT SUPPORT

Product Support

Racal Instruments has a complete Service and Parts Department. If you need technical assistance or should it be necessary to return your product for repair or calibration, call 1-800-722-3262. If parts are required to repair the product at your facility, call 1-949-859-8999 and ask for the Parts Department.

When sending your instrument in for repair, complete the form in the back of this manual.

For worldwide support and the office closes to your facility, refer to the Support Offices section on the following page.

Reshipment Instructions

Use the original packing material when returning the 1260-134 to Racal Instruments for calibration or servicing. The original shipping crate and associated packaging material will provide the necessary protection for safe reshipment.

If the original packing material is unavailable, contact Racal Instruments Customer Service for information.

Support Offices

RACAL INSTRUMENTS

United States

(Corporate Headquarters and Service Center)
4 Goodyear Street, Irvine, CA 92618
Tel: (800) 722-2528, (949) 859-8999; Fax: (949) 859-7139

5730 Northwest Parkway Suite 700, San Antonio, TX 78249
Tel: (210) 699-6799; Fax: (210) 699-8857

Europe

(European Headquarters and Service Center)
18 Avenue Dutartre, 78150 LeChesnay, France
Tel: +33 (0)1 39 23 22 22; Fax: +33 (0)1 39 23 22 25

29-31 Cobham Road, Wimborne, Dorset BH21 7PF, United Kingdom
Tel: +44 (0) 1202 872800; Fax: +44 (0) 1202 870810

Via Milazzo 25, 20092 Cinisello B, Milan, Italy
Tel: +39 (0)2 6123 901; Fax: +39 (0)2 6129 3606

Technologie Park, Friedrich Ebert Strasse, 51429 Bergisch Gladbach,
Germany
Tel: +49 (0) 2204 844200; Fax: +49 (0) 2204 844219

REPAIR AND CALIBRATION REQUEST FORM

To allow us to better understand your repair requests, we suggest you use the following outline when calling and include a copy with your instrument to be sent to the Racal Repair Facility.

Model _____ Serial No. _____ Date _____

Company Name _____ Purchase Order # _____

Billing Address _____

City

State/Province

Zip/Postal Code

Country

Shipping Address _____

City

State/Province

Zip/Postal Code

Country

Technical Contact _____ Phone Number () _____

Purchasing Contact _____ Phone Number () _____

1. Describe, in detail, the problem and symptoms you are having. Please include all set up details, such as input/output levels, frequencies, waveform details, etc.

2. If problem is occurring when unit is in remote, please list the program strings used and the controller type.

3. Please give any additional information you feel would be beneficial in facilitating a faster repair time (i.e., modifications, etc.)

4. Is calibration data required? Yes No (please circle one)

Call before shipping

Ship instruments to nearest support office.

Note: We do not accept
"collect" shipments.